

2021

SFM
胜 福 美 电 热

**Foshan Shunde
Shengfumei Electric
Heating Technology
Co., LTD**

The main: cartridge heater



SFM

胜福美电热

cartridge heater



L shape Cartridge Heater



Type with accessories Cartridge Heater

(Acceptable customization)



Flanges with fins Cartridge Heater



In the lead Cartridge Heater

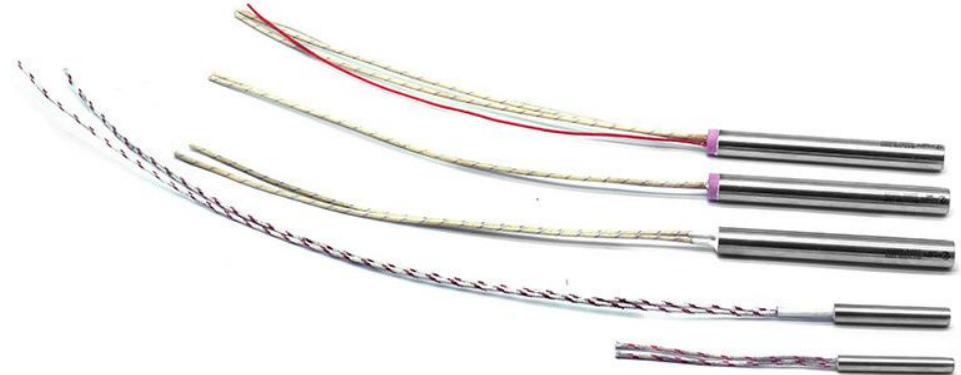

3D hot bending machine Cartridge Heater



1: Different styles can be customized

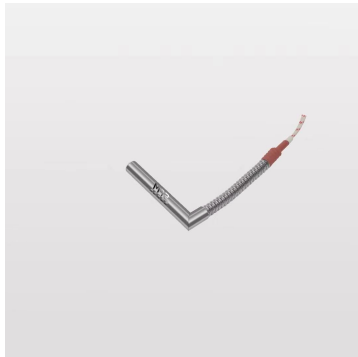

2: Different voltages and powers can be customized



220V electric heating tube connected to 380V



220V connected to 220V in parallel



2. The heating pipe is wired in the correct way. Misconnecting the line will lead to slow heating and burning out the heating pipe. The two common ways for customers are shown in the figure above. (Please refer to)

3: Details about it



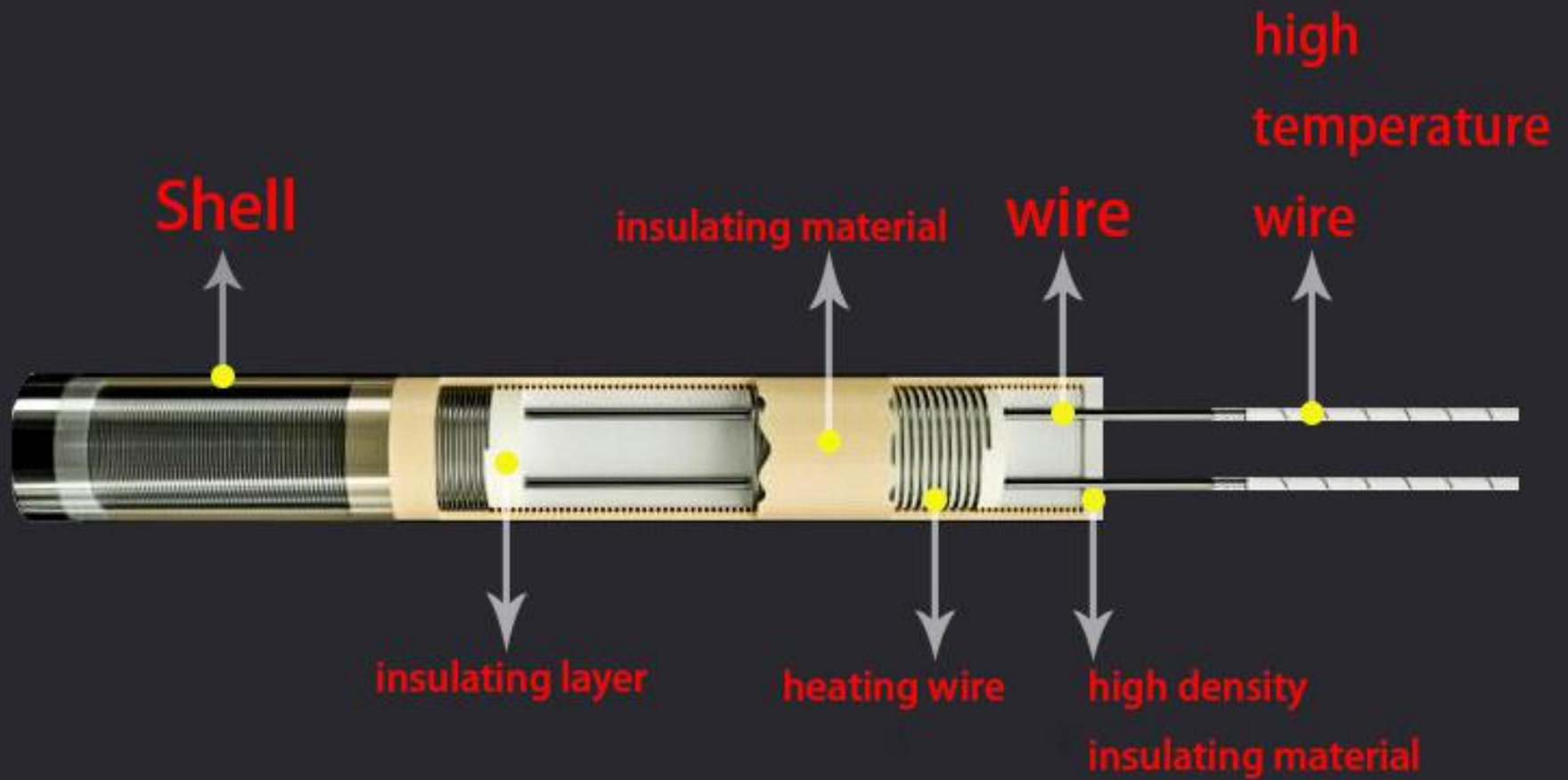

DIRECTIONS FOR USE



1. Before installation, use a **multimeter** to measure whether the heating element is energized. If there is no problem with the measurement of the multimeter, then install it. If the heating element is not energized, please contact customer service.

PRODUCT STRUCTURE DRAWING

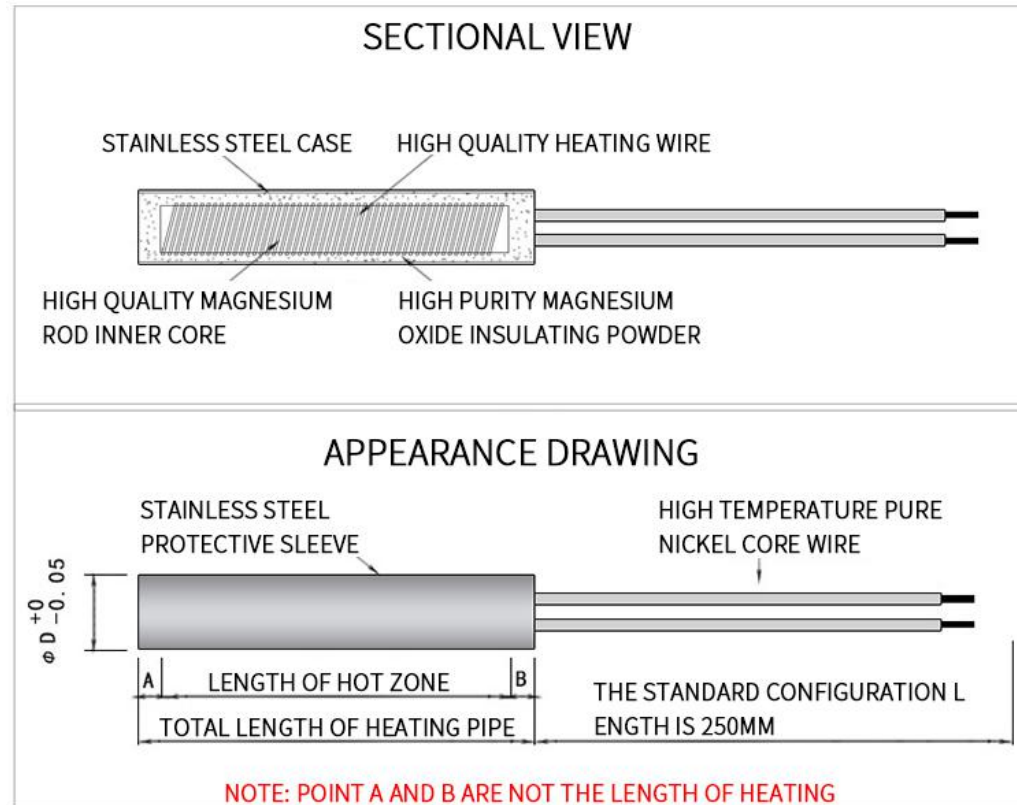

ADOPT HIGH QUALITY 500°C TO 800°C RESISTANT HIGH PURITY NICKEL CORE WIRE TO AVOID SHORT CIRCUIT CAUSED BY EASY CONTACT OF LEAD WIRE JOINT. SUITABLE FOR MOLD HEATING.

Quality inspection

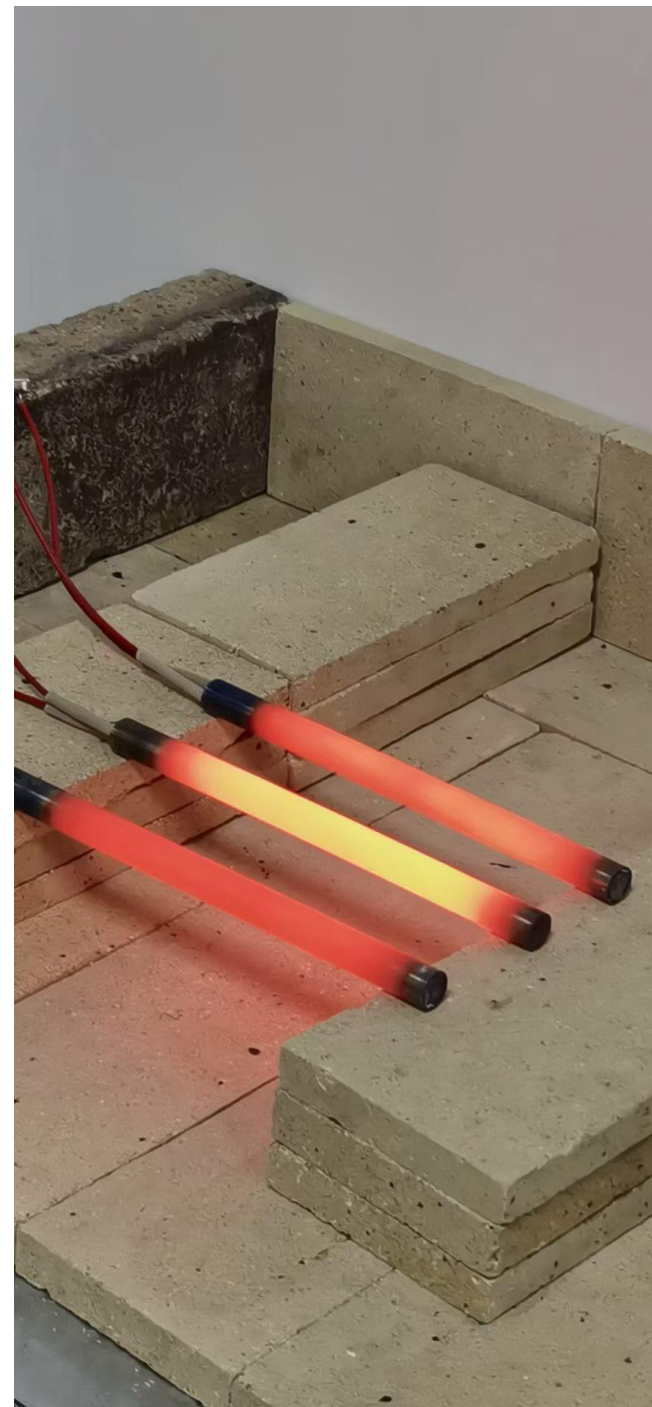
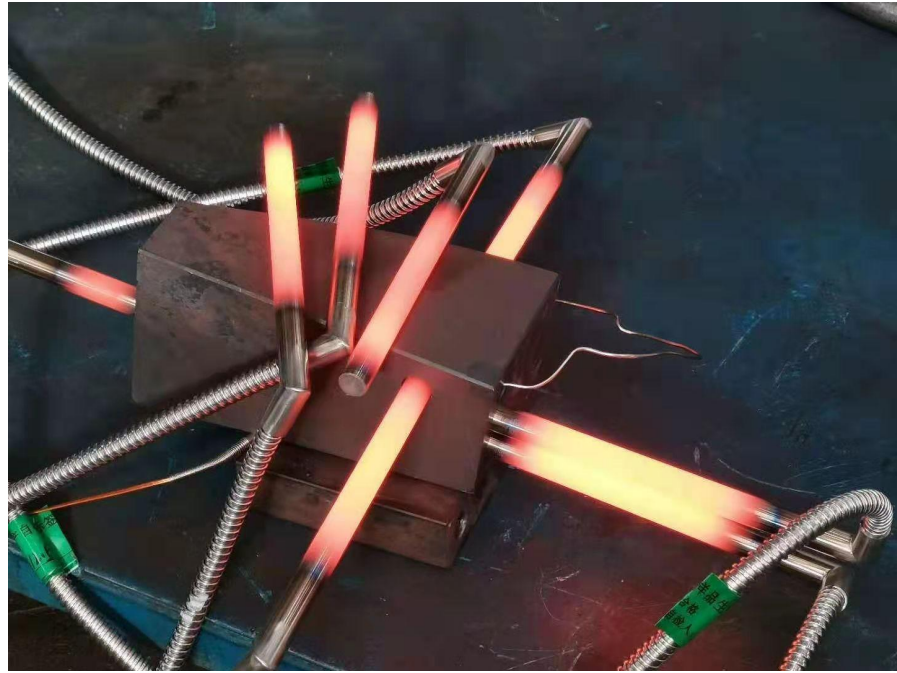

Craft show

Process display



Automatic wire



Automatically around the core



Tube rolling process



Pipe cutting process



Automatic blanking



Detection technology



Laser printing



Vacuum packing

SFM
胜福美电热

Application field

- ※ Mould heating
- ※ Hot melt adhesive
- ※ Embryo bottle mould
- ※ Semiconductor industry
- ※ Pharmaceutical equipment
- ※ Die casting industry
- ※ Packaging industry
- ※ Rubber molding industry
- ※ Textile industry - Hot knife
- ※ Extrusion line
- ※ Paper industry - embossing roller
- ※ The sealing device
- ※ Biofuel ignition equipment
- ※ 3 d printer
- ※ 3D hot bending machine equipment



Style structure

Wire type

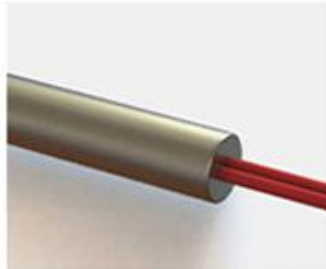

The qualification



Outside the line

Electric heat pipe type



Extension of the cold end



Variable power



With ceramic head



With a thermocouple

Wire sheath



Fiberglass sleeve



Metal woven sleeve



Metal woven sleeve

Line structure

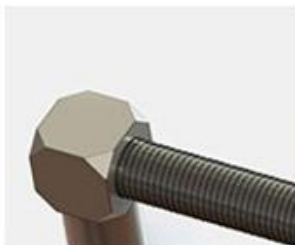

90° armored cable

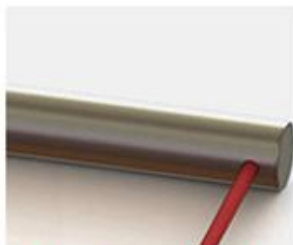

90° pipe wall outlet



braided wire



armored cable



90° square head outlet

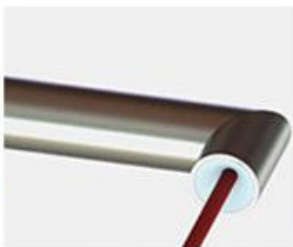

90° pipe sleeve at right angles



Ceramic beads

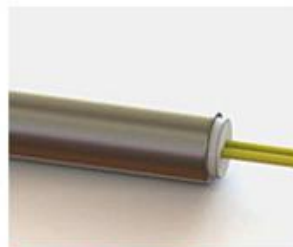

Ceramic head with internal outlet

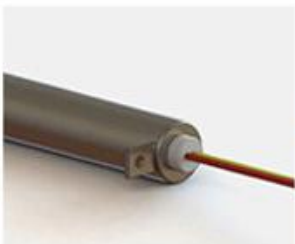

Install the clip

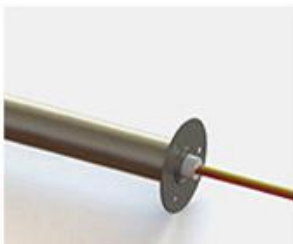

Installation of flange



The silicone seal



Stainless steel + braided wire



Armoured cable

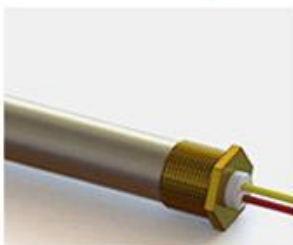

The bottom of the thread

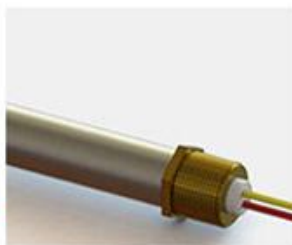

Screw cap

SFM
胜福美电热

Shipment of the product



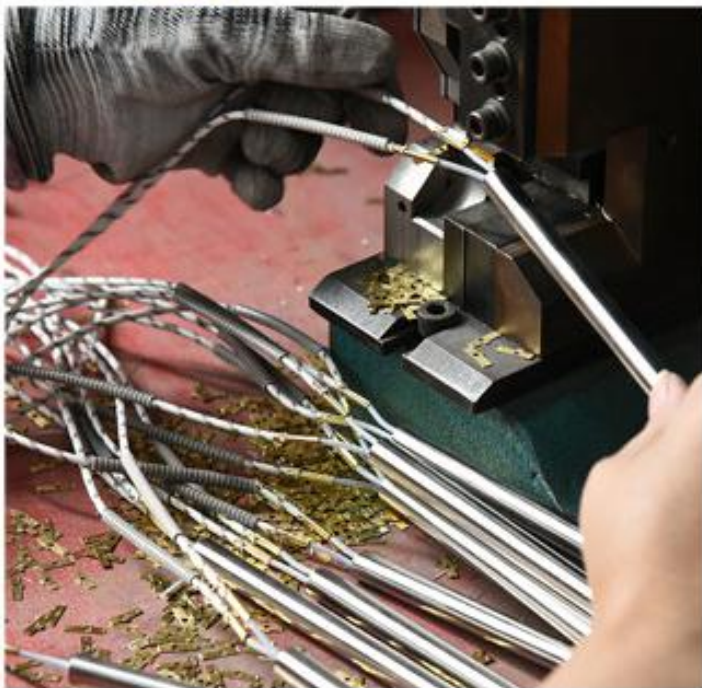



company environment



SFM
胜福美电热

SAMFUL
SALES MANAGER



✉ sfm13726318942@163.com

☎ 86 13726318942

📘 shengfu Zeng